

NOTICE TO INSTALLER: Instructions must remain with installation.

SECTION: 6.10.082

*"QUALITY PUMPS SINCE 1939"*

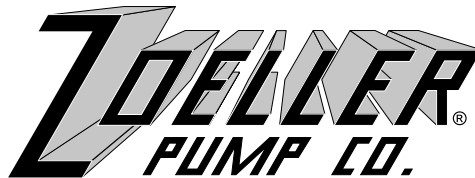

FM2540

1208

Supersedes

1108

Product information presented here reflects conditions at time of publication. Consult factory regarding discrepancies or inconsistencies.

visit our web site:  
[www.deanbennett.com](http://www.deanbennett.com)



MODEL 503

## WATER POWERED EMERGENCY BACKUP SUMP PUMP SYSTEM

### PREINSTALLATION CHECKLIST

1. **Inspect your pump.** Occasionally, products are damaged during shipment. If the unit or any of the parts are damaged, contact your dealer before using.
2. **Read all the installation instructions** regarding installing and start up. Retain for future reference.



**WARNING**

SEE BELOW FOR LIST OF WARNINGS

1. **For your protection always disconnect the power supply** from its power source before handling the components of your primary pump.

**CAUTION**

SEE BELOW FOR LIST OF CAUTIONS

1. This pump is designed for handling clear water. Do not use in septic tanks to pump effluent or sewage pits to pump sewage.
2. Repair and service of your backup system should be performed by an authorized service station.
3. The installation of this backup pump requires the use of a variable level float switch for operation. It is the responsibility of the installing party, to ensure that the float switch will not hang up on the pump apparatus or

pit peculiarities and is secured so the pump will turn "on" and "off". It is recommended that the pit be 18" in diameter or larger to accommodate both a primary and a backup pump.

4. Check the installation of the primary and backup pump floats to ensure that both move freely and are not being encroached upon where the float cannot move. Adequate space between the floats must be maintained.
5. The pump should be manually activated once a month by lifting the float rod. Let the pump run for at least 15 seconds to prevent the pump from building up calcium deposits and debris, which could harm the pump.

**CAUTION** Turbulence caused by high velocity incoming water can negatively affect the on/off action of the float mechanism. If this condition exists, the incoming water must be baffled to avoid excessive turbulence.

REFER TO WARRANTY ON PAGE 2.

## Limited Warranty

Manufacturer warrants, to the purchaser and subsequent owner during the warranty period, every new product to be free from defects in material and workmanship under normal use and service, when properly used and maintained, for a period of two years from date of manufacture. Parts that fail within the warranty period, that inspections determine to be defective in material or workmanship, will be repaired, replaced or remanufactured at Manufacturer's option, provided however, that by so doing we will not be obligated to replace an entire assembly, the entire mechanism or the complete unit. No allowance will be made for shipping charges, damages, labor or other charges that may occur due to product failure, repair or replacement.

This warranty does not apply to and there shall be no warranty for any material or product that has been disassembled without prior approval of Manufacturer, subjected to misuse, misapplication, neglect, alteration, accident or act of God; that has not been installed, operated or maintained in accordance with Manufacturer's installation instructions; that has been exposed to outside substances including but not limited to the following: sand, gravel, cement, mud, tar, hydrocarbons, hydrocarbon derivatives (oil, gasoline, solvents, etc.), or other abrasive or corrosive substances, wash towels or feminine sanitary products, etc. in all pumping applications. The warranty set out in the paragraph above is in lieu of all other warranties expressed or implied; and we do not authorize any representative or other person to assume for us any other liability in connection with our products.

Contact Manufacturer at, 3649 Cane Run Road, Louisville, Kentucky 40211, Attention: Customer Service Department to obtain any needed repair or replacement of part(s) or additional information pertaining to our warranty.

**MANUFACTURER EXPRESSLY DISCLAIMS LIABILITY FOR SPECIAL, CONSEQUENTIAL OR INCIDENTAL DAMAGES OR BREACH OF EXPRESSED OR IMPLIED WARRANTY; AND ANY IMPLIED WARRANTY OF FITNESS FOR A PARTICULAR PURPOSE AND OF MERCHANTABILITY SHALL BE LIMITED TO THE DURATION OF THE EXPRESSED WARRANTY.**

Some states do not allow limitations on the duration of an implied warranty, so the above limitation may not apply to you. Some states do not allow the exclusion or limitation of incidental or consequential damages, so the above limitation or exclusion may not apply to you.

This warranty gives you specific legal rights and you may also have other rights which vary from state to state.

## Installation

The HOME GUARD® MAX pump can be installed very easily as a standby to an electric sump pump (see sketches). However, a check valve is required between the electric pump and the HOME GUARD® MAX.

**Note 1:** Per the Uniform Plumbing Code and the Plumbing Codes of some states, installation of this product requires the use of a RPZ backflow protection device. Contact your local plumbing or water authority for more information regarding the requirements for your specific area.

**Note 2:** Per the Uniform Plumbing Codes and IAPMO PS119, the discharge of the water-powered sump pump should not be connected to the discharge of the primary sump pump.

### Dimensions

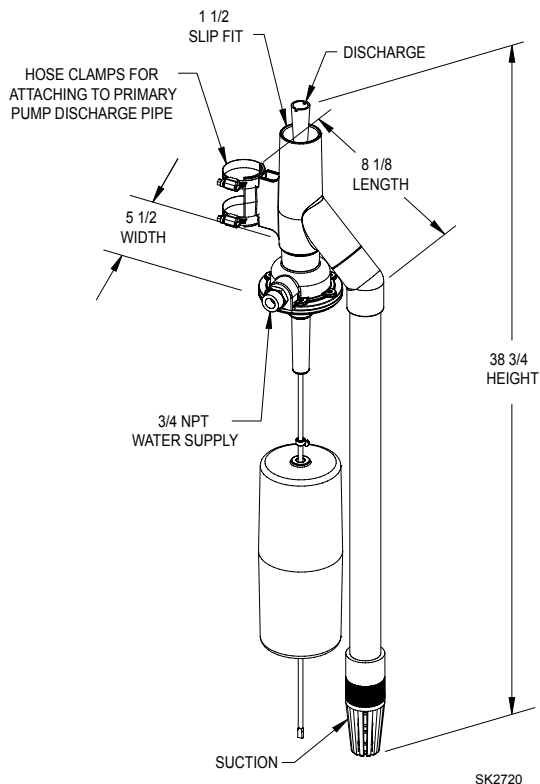

### WATER PRESSURE:

20 PSI minimum with valve open.  
80 PSI maximum with valve open.  
100 PSI maximum with valve closed.

### Typical Installation with Submersible Pump and Separate Discharge Pipe

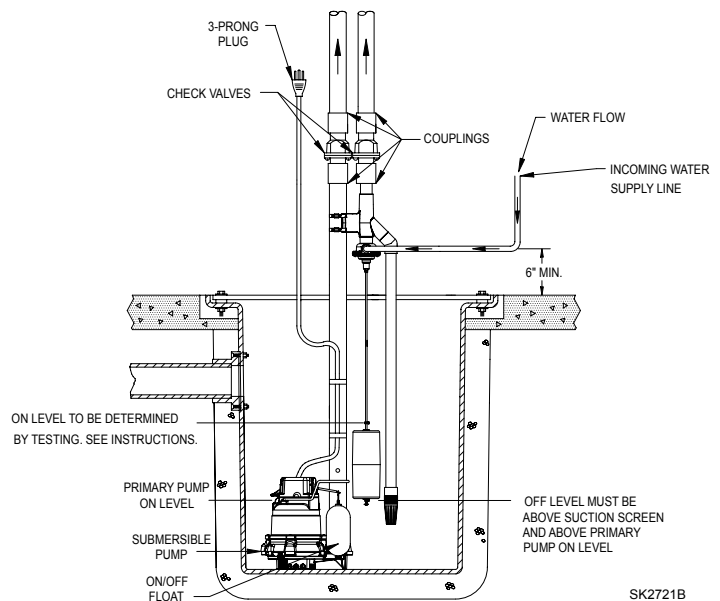

### EFFICIENCY:

The pumping capacity increases with household water pressure and flow.

At an eight-foot static head and a supply pressure of 20 PSI at water supply inlet with water flowing, it takes one (1) gallon of supply water to remove one gallon from the sump. As the supply pressure increases with the static head constant, less supply water is required.